

**THREE-PHASE MOTOR:** From 6 up to 25 CV (4.5 / 18.5 kW)  
 230 V-400 V-415 V ; (50/60 HZ)  
**MONO-PHASE MOTOR:** From 2 up to 8 CV (1.5 / 4.5 kW)  
**PUMP:** From 30 up to 210 L/min.  
**PRESSURE:** From 12 up to 45 BAR

OIL QUANTITY	
MINIMUM LEVEL	65 litres
USEFUL OIL	150 litres
TOTAL OIL	215 litres

  

POWER UNIT WEIGHT WITHOUT OIL	136 KG
-------------------------------	--------

**NOTE:**

- DISTRIBUTOR: 15-250 L/1'
- REF TABLE # 9017, TO CHOOSE PUMP AND POWER MOTOR
- OUTLET ( \* ) WITH FLEX-PIPE 1" (M36x2) FOR PUMP UNTIL 150 L/min (OPTIONAL)
- OUTLET ( \* ) WITH FLEX-PIPE 1"1/4 (M45x2) FOR PUMP UNTIL 150 L/min
- OUTLET ( \* ) WITH FLEX-PIPE 1"1/2 (M52x2)  
FOR PUMP From 180 L/min. up to 210 L/min.
- AUXILIARY TANK AGAINST POWER UNIT OIL SPILLS: SEE TAB. 9291
- CABINET ARRANGEMENT: SEE CAP.16
- HEAT EXCHANGER ARRANGEMENT ( \*\* OPTIONAL )

UT		<b>DATA SHEET</b> <b>POWER UNIT CM-MARK2</b>	DATE	07/18
			DWG Nr.	9018/CM-MK2

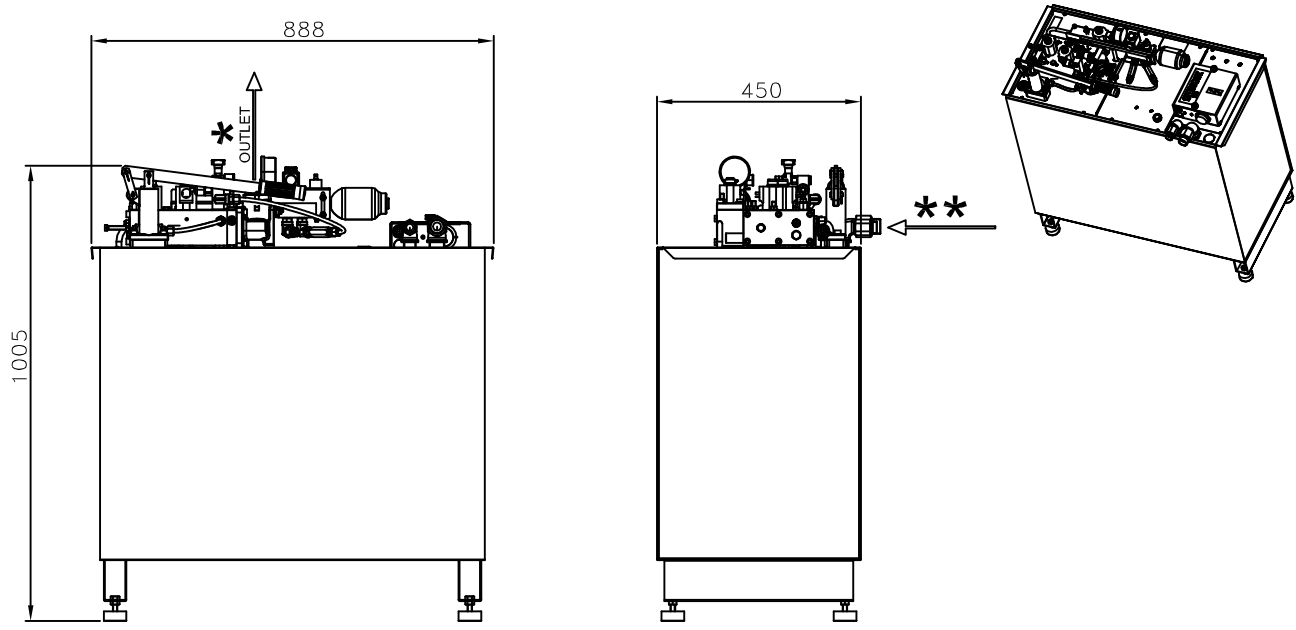

**THREE-PHASE MOTOR:** From 6 up to 25 CV (4.5 / 18.5 kW)  
 230 V-400 V-415 V ; (50/60 HZ)  
**MONO-PHASE MOTOR:** From 2 up to 8 CV (1.5 / 4.5 kW)  
**PUMP:** From 30 up to 210 L/min.  
**PRESSURE:** From 12 up to 45 BAR

OIL QUANTITY	
MINIMUM LEVEL	65 litres
USEFUL OIL	150 litres
TOTAL OIL	215 litres

  

POWER UNIT WEIGHT WITHOUT OIL	126 KG
-------------------------------	--------

**NOTE:**

- DISTRIBUTOR: 15-250 L/1'
- REF TABLE # 9017, TO CHOOSE PUMP AND POWER MOTOR
- OUTLET ( \* ) WITH FLEX-PIPE 1" (M36x2) FOR PUMP UNTIL 150 L/min (OPTIONAL)
- OUTLET ( \* ) WITH FLEX-PIPE 1"1/4 (M45x2) FOR PUMP UNTIL 150 L/min
- OUTLET ( \* ) WITH FLEX-PIPE 1"1/2 (M52x2)  
FOR PUMP From 180 L/min. up to 210 L/min.
- AUXILIARY TANK AGAINST POWER UNIT OIL SPILLS: SEE TAB. 9291
- CABINET ARRANGEMENT: SEE CAP.16
- HEAT EXCHANGER ARRANGEMENT ( \*\* OPTIONAL )

UT		<b>DATA SHEET</b> <b>POWER UNIT CM-MARK2-A</b>	DATE 07/18
			DWG Nr. 9018/CM-MK2-A

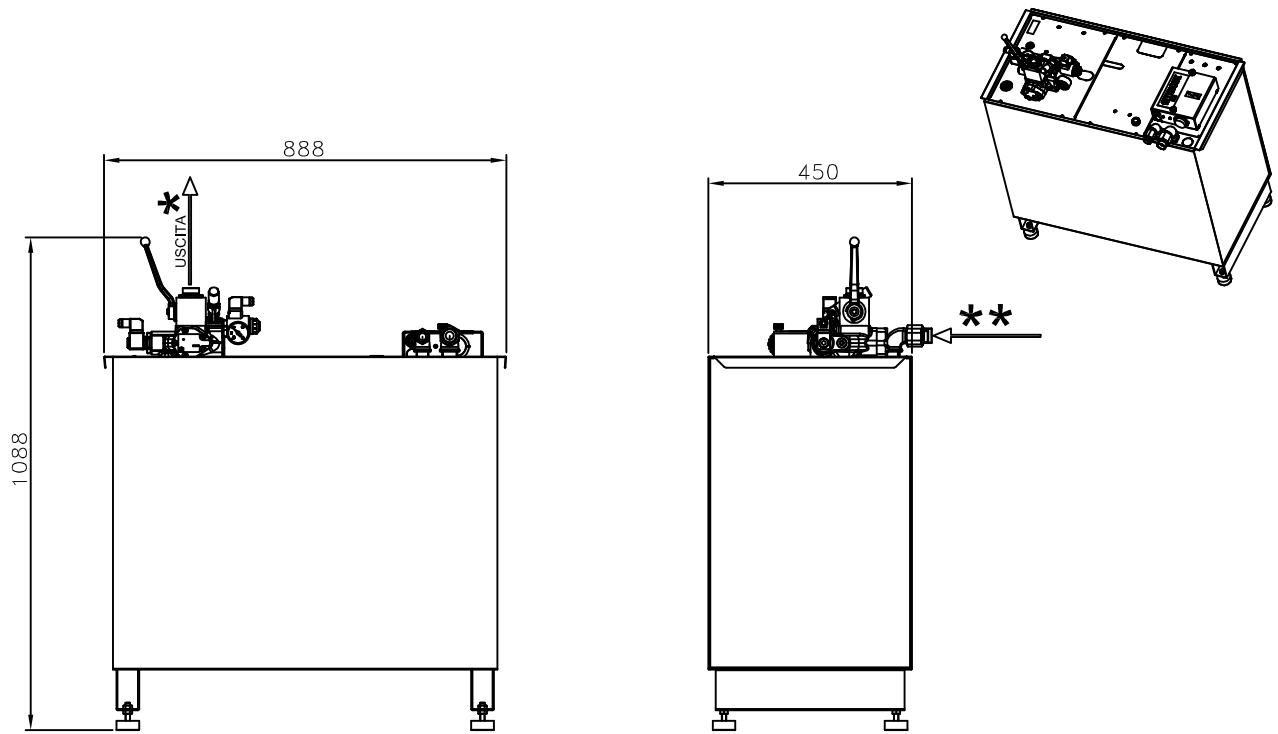

**THREE-PHASE MOTOR:** From 6 up to 25 CV (4.5 / 18.5 kW)  
 230 V-400 V-415 V ; (50/60 HZ)  
**MONO-PHASE MOTOR:** From 2 up to 8 CV (1.5 / 4.5 kW)  
**PUMP:** From 30 up to 210 L/min.  
**PRESSURE:** From 12 up to 60 BAR

OIL QUANTITY	
MINIMUM LEVEL	65 litres
USEFUL OIL	150 litres
TOTAL OIL	215 litres
POWER UNIT WEIGHT WITHOUT OIL	126 KG

**NOTE:**

- DISTRIBUTOR: I-VALVE 250/250 (180-210 l/min); I-VALVE 250/160 (until 150 l/min)
- REF TABLE # 9017, TO CHOOSE PUMP AND POWER MOTOR
- OUTLET (\*) WITH FLEX-PIPE 1" (M36x2)
- OUTLET (\*) WITH FLEX-PIPE 1"1/4 (M45x2)
- OUTLET (\*) WITH FLEX-PIPE 1"1/2 (M52x2)
- AUXILIARY TANK AGAINST POWER UNIT OIL SPILLS: SEE TAB. 9291
- CABINET ARRANGEMENT: SEE CAP.16
- HEAT EXCHANGER ARRANGEMENT (\*\* OPTIONAL)

UT	

**DATA SHEET**  
**POWER UNIT CM-MARK2-IV**

DATE	07/18
DWG Nr.	9018/CM-MK2-IV